

## TECHNICAL SPECIFICATIONS

### ROCKCRUSHER 7 R

Hydraulic power	27 kW
Oil flow rate	100 l/min
Oil pressure max	220 bar
Rotation	350 rpm
Weight	2 000kg
Excavator size	> 12 t
Inlet opening	650 x 500 mm
Rated capacity [acc. ISO 7451]	0,5 m <sup>3</sup>
CSS toggle min - max	10 - 100
Feed line	3/4" 6000 psi flange
Return line	3/4" 6000 psi flange
Drain line	1/2" 3000 psi flange
Hydraulic motor	60 cc



## TECHNICAL SPECIFICATIONS ROCKCRUSHER 7 R

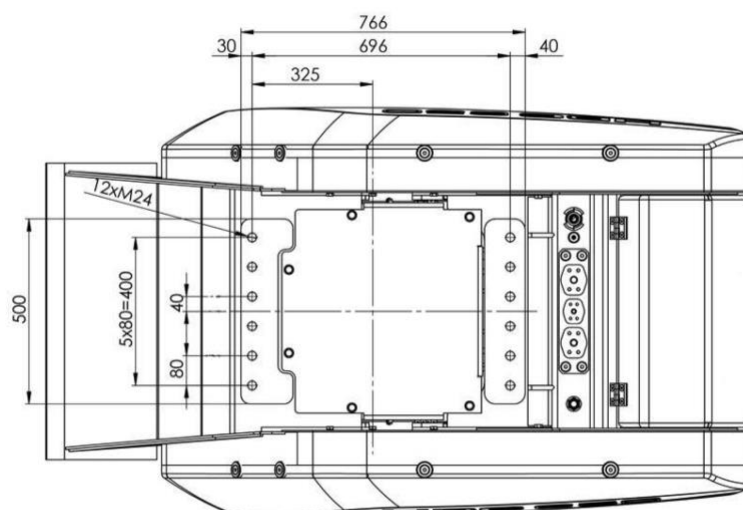
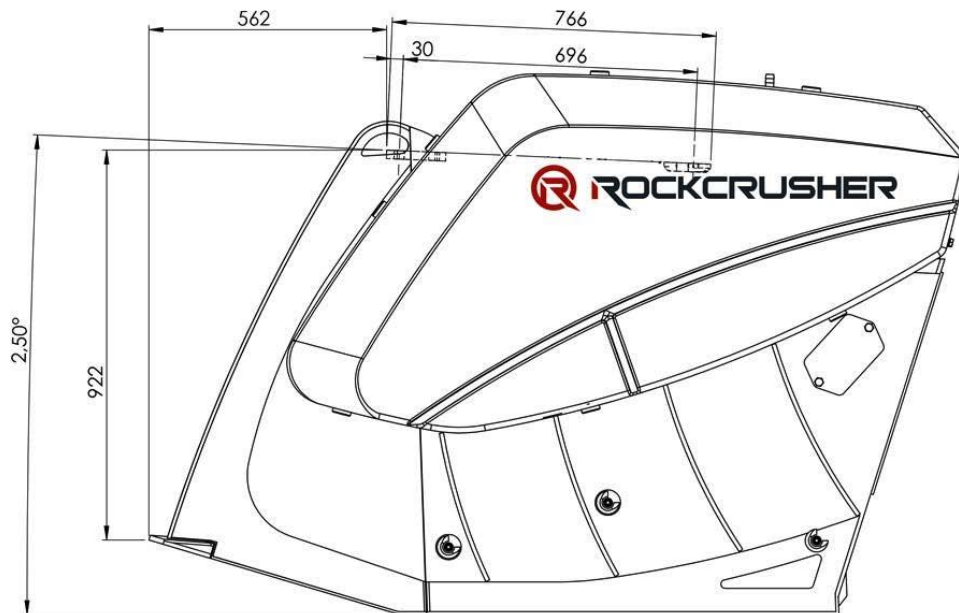

## TECHNICAL SPECIFICATIONS ROCKCRUSHER 9 R

Hydraulic power	40 kW
Oil flow rate	145 l/min
Oil pressure max	220 bar
Rotation	350 rpm
Weight	3 000kg
Excavator size	> 20 t
Inlet opening	750 x 500 mm
Rated capacity [acc. ISO 7451]	0,8 m <sup>3</sup>
CSS toggle min - max	40 - 100
Feed line	1" 6000 psi flange
Return line	1 " 6000 psi flange
Drain line	1/2" 3000 psi flange
Hydraulic motor	80 cc



## TECHNICAL SPECIFICATIONS ROCKCRUSHER 9 R

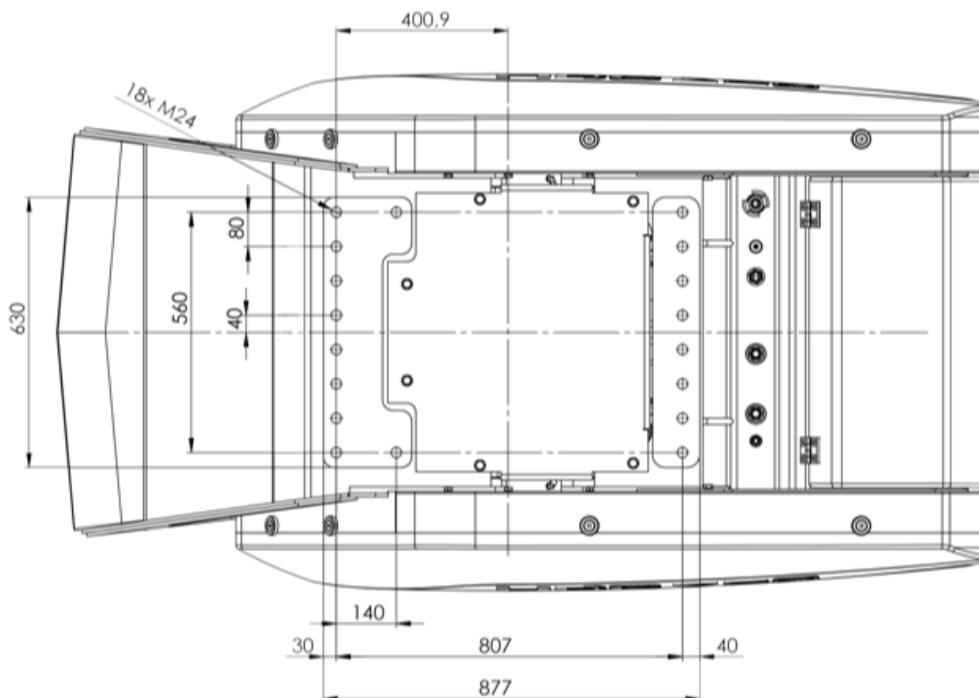
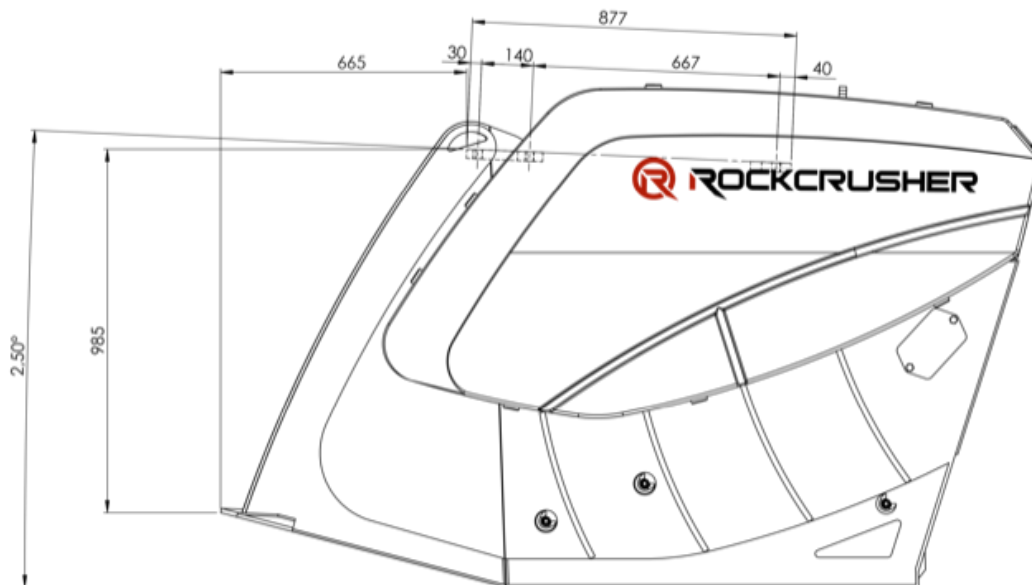

## TECHNICAL SPECIFICATIONS

### ROCKCRUSHER 11 R

Hydraulic power	54 kW
Oil flow rate	200 l/min
Oil pressure max	220 bar
Rotation	350 rpm
Weight	4 100kg
Excavator size	> 25 t
Inlet opening	950 x 525 mm
Rated capacity [acc. ISO 7451]	1,0 m <sup>3</sup>
CSS toggle min - max	45 - 100
Feed line	1" 6000 psi flange
Return line	1 " 6000 psi flange
Drain line	1/2" 3000 psi flange
Hydraulic motor	80 cc



## TECHNICAL SPECIFICATIONS ROCKCRUSHER 11 R

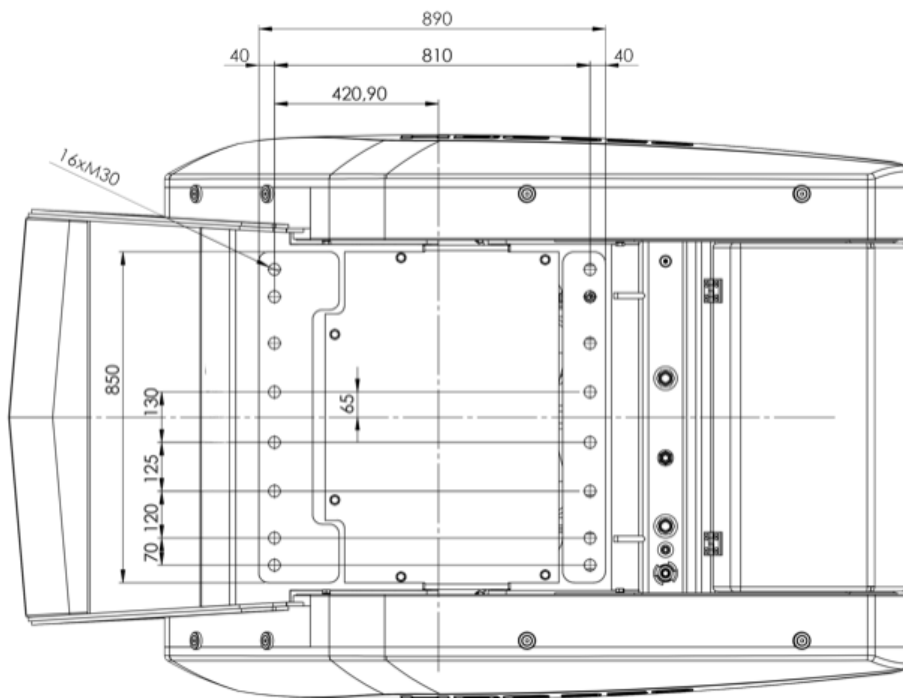
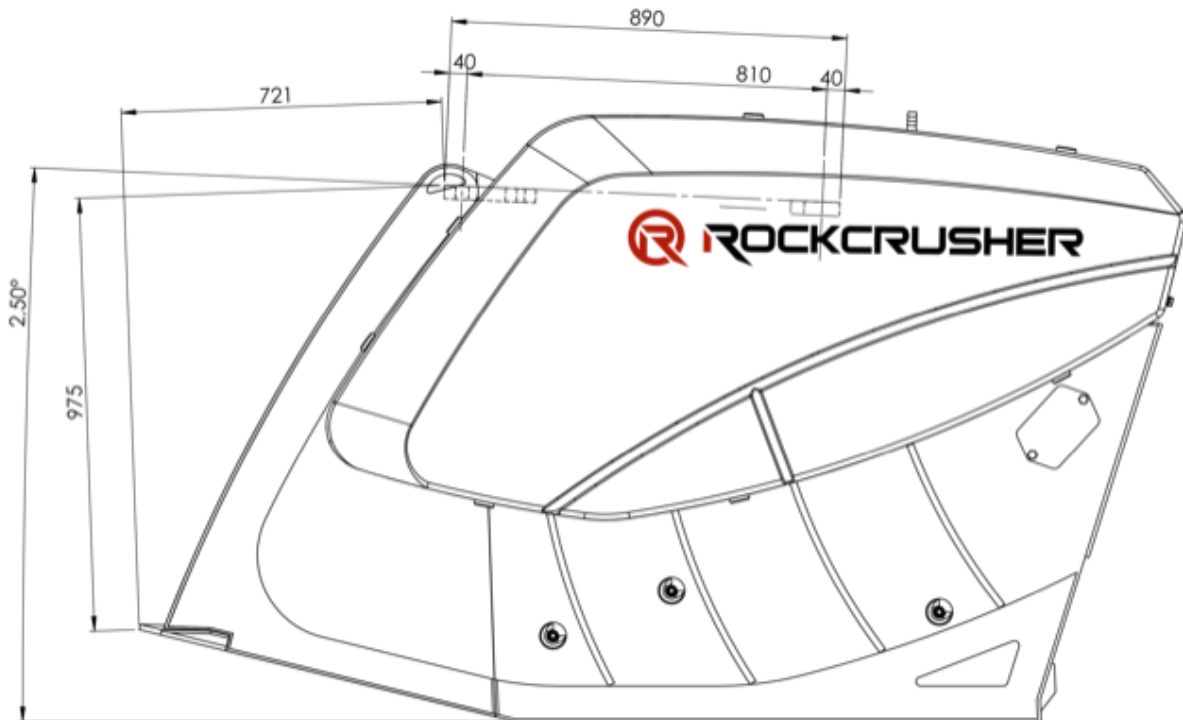

## TECHNICAL SPECIFICATIONS

### ROCKCRUSHER 13 R

Hydraulic power	79 kW
Oil flow rate	290 l/min
Oil pressure max	220 bar
Rotation	350 rpm
Weight	6 100kg
Excavator size	> 35 t
Inlet opening	1250 x 570 mm
Rated capacity [acc. ISO 7451]	1,7 m <sup>3</sup>
CSS toggle min - max	45 - 120
Feed line	1 1/4" 6000 psi flange
Return line	1 1/4 " 6000 psi flange
Drain line	1/2" 3000 psi flange
Hydraulic motor	150 cc



## TECHNICAL SPECIFICATIONS ROCKCRUSHER 13 R

